

FORGED BELLOW SEAL GATE VALVE

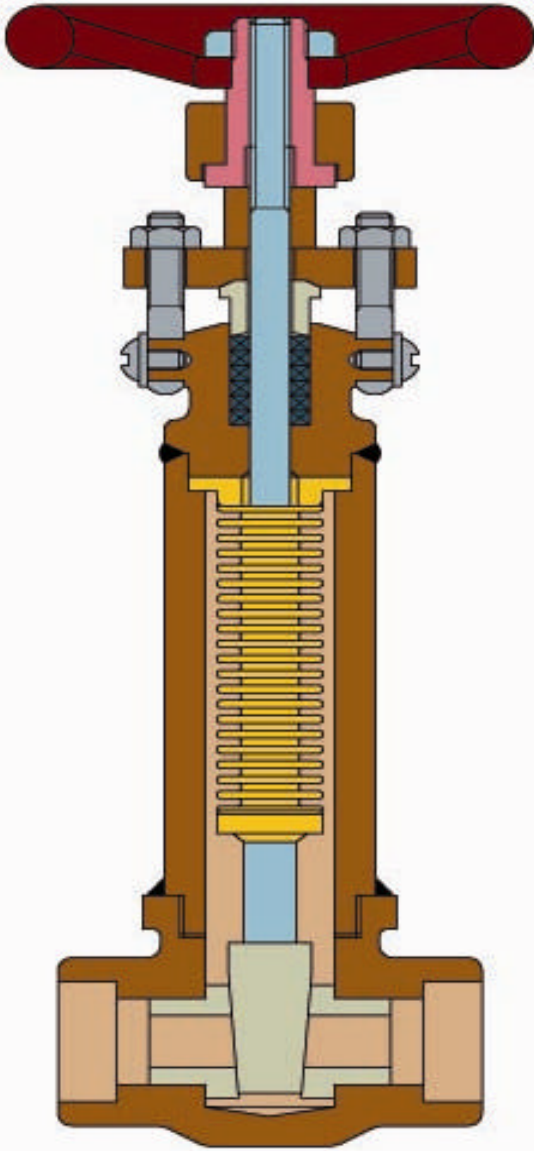

SR.No.	PARTS	MATERIAL
1	BODY	A-105 / A 182 Gr. F304 / F316
2	SEAT RING	AISI-410 / AISI-304 / 316
3	WEDGE	AISI-410 / AISI-304 / 316
4	STEM	AISI-410 / AISI-304 / 316
5	BELLOW	AISI-321 / 316L / 316Ti
6	BONNET	A-105 / A 182 Gr. F304 / F316
7	GLAND PACKING	GRAPHITE / PTFE
8	GLAND BUSH	AISI-410 / AISI-304 / 316
9	GLAND FLANGE	A-105/C.S. / AISI-304 / 316
10	YOKE SLEEVE	NI-RESIST
11	HAND WHEEL	C.S. FABRICATED
12	CYLINDER	C.S. FABRICATED
13	BELLOW COLLAR	AISI-316
14	TOP COLLAR	AISI-316
15	SCREW	STD.
16	HANDWHEEL NUT	C.S. / AISI-410 / AISI-304/316

TECHNICAL DATA

- Face to Face as per Manufacturers spec.
- Socket Weld end as per ANSI -B- 16.11
- Butt Weld End as per ANSI -B- 16.25 with End Pups
- Screwed End as per ANSI -B- 1.20.1 (NPT)
- Valve Designed to API - 602
- Valve Tested to API - 598 / BS - 5146

OPTIONAL

- Geared Actuators
- Pneumatic Actuators
- Electric Actuators

TEST PRESSURE	150 #	300 #
BODY (HYDRO)	32 Kg/cm ²	76 Kg/cm ²
SEAT (HYDRO)	23 Kg/cm ²	55 Kg/cm ²
SEAT (AIR)	07 Kg/cm ²	07 Kg/cm ²

CLASS : 150

SIZE - NB (MM)	8	10	15	20	25	32	40	50
FACE TO FACE	70	70	80	85	95	105	125	145
SOCKET DIAMETER	14.1	17.53	21.72	27.05	33.78	42.54	48.64	61.11
SOCKET DEPTH	9.6	9.6	9.6	12.7	12.7	12.7	12.7	15.8